

# Urban Auclair

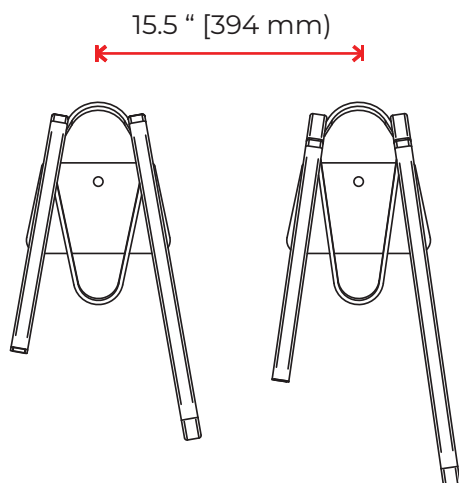
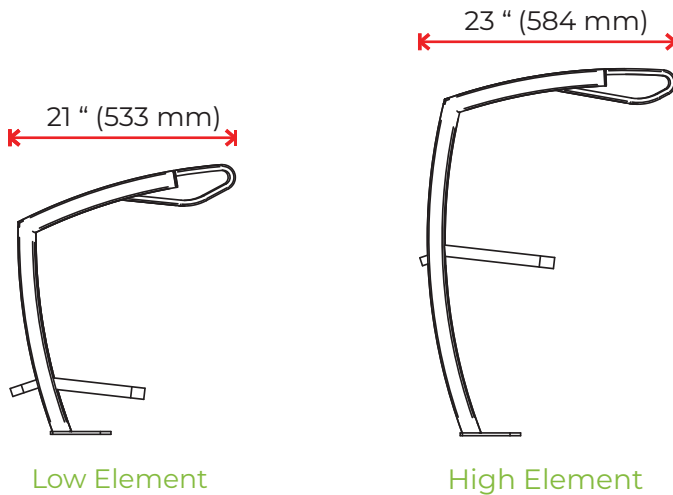
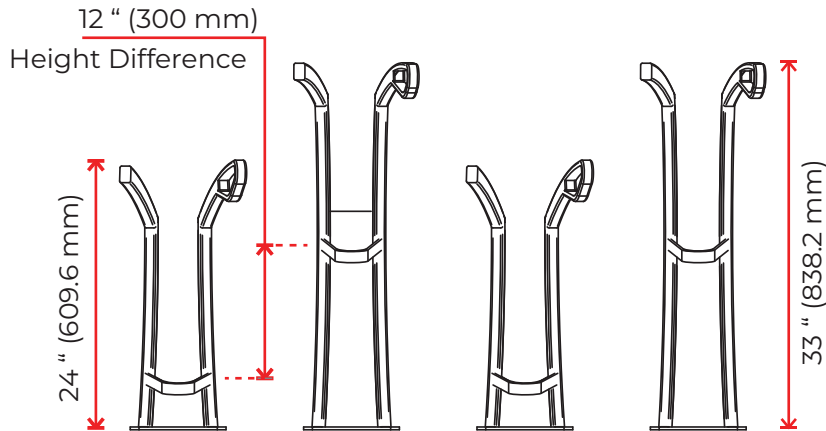

## Capacity

Number of Bicycles	1
Minimum Spacing	15.5 " [394 mm]
Height Alternance	12 " [300mm]

## Weight

High Element	8kg (18 lbs)
Low Element	6.5kg (15 lbs)

## Materials

Assembly Material	Steel
Locking Loop	.5 x 1 " [12.7 x 25 mm] Rod

## Anti-theft Feature

Optional Tamper-proof Security Bolts

## Available Finishes

- Power Coated
- Hot-Dipped Galvanized
- 304 Stainless Steel



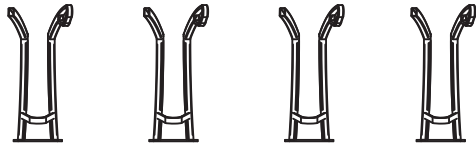

All Low Elements

Minimum 24 " (60cm) Spacing  
Side Clearance at Least 12 " (30 cm)

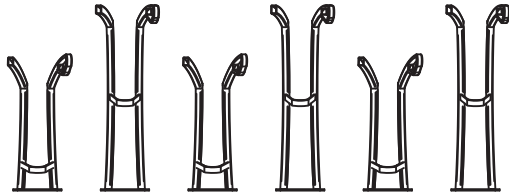

High and Low Elements

Minimum 15.5 in [393 mm] Spacing  
Side Clearance at Least 12 in [30 cm]

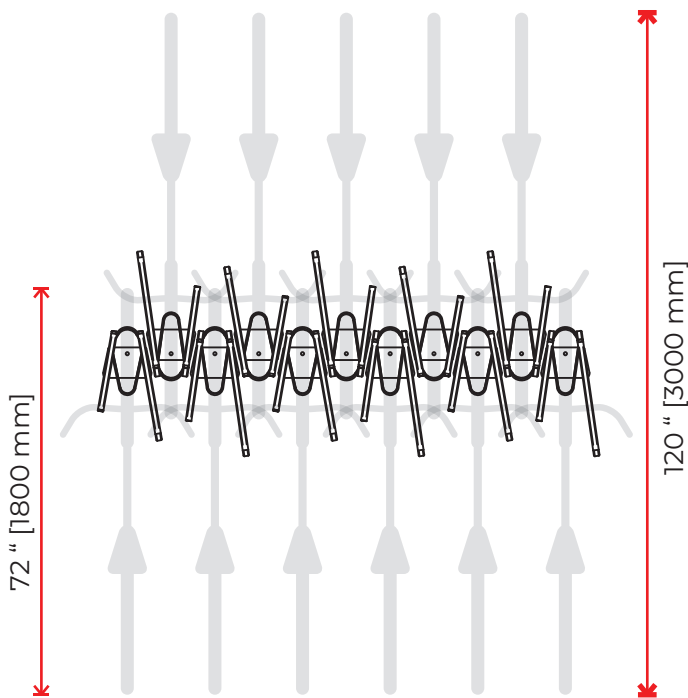

Front and back

Minimum 7.75 [196 mm] spacing  
Side clearance at least 12 in [30 cm]  
Align racks on central anchor point

Aisle width

An aisle width of 72 in [1.75 m] is typically regarded as sufficient even in the presence of a moderately high number of cyclists, although additional space may be required when aisle lengths are longer than usual to prevent bottlenecks. As a general rule, more space results in a more pleasant experience for the cyclists.

If cyclists are expected to be able to use their bicycle in the facilities, an aisle width of no less than 10 feet [3 m] should be used.

Mavoeuvering space for angled parking

When using angled parking, mavoeuvering space requirements are reduced, allowing a very compact bike parking solution. At 45°, 40 in [1 m] is sufficient to park a bicycle without being inconvenienced. This configuration is recommended, for example, on sidewalks in front of buildings when little space is available but bicycle parking requirements are high.

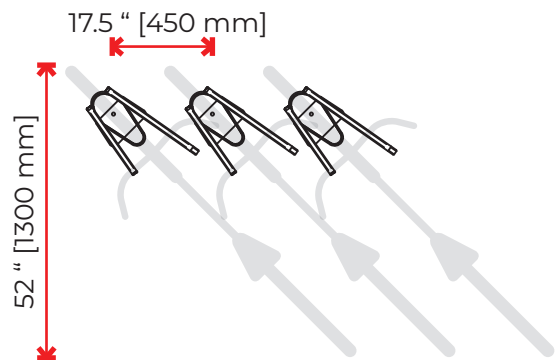

45 Degree Angle

Horizontal Spacing 17.5 in [450 mm]  
Align Racks on Central Anchor Point.



These drawings are not for construction purposes and are for information purposes only. All information contained herein was current at the time of development but must be reviewed and confirmed by Urban Racks to be considered accurate.

[www.urbanracks.com](http://www.urbanracks.com) | [sales@urbanracks.com](mailto:sales@urbanracks.com)  
+1-888-717-8881 | [@urbanracks](https://www.urbanracks.com)

© 2020 Urban Racks Bicycle Parking Systems Inc. All Rights Reserved.

