

# Urban Staple Racks - Installation Guidelines

Model: Various

The ground mounted Urban Staple Racks need to be anchored to a concrete surface to ensure a stable and safe installation. Minimum concrete specifications should be observed as follows:

## MINIMUM CONCRETE REQUIREMENTS

Recommended Pad Size, Single Rack: 36" x 18"  
Thickness: 4-6" - minimum 4"  
For new concrete, allow up to ten days for cure before installing anchors

## Tools Required

Ratchet with Extension or Drill/Driver  
3/4" Deep Socket with Extension  
1/2" Masonry Drill Bit  
Hammer Drill (optional)  
Hammer  
Personal Safety Equipment

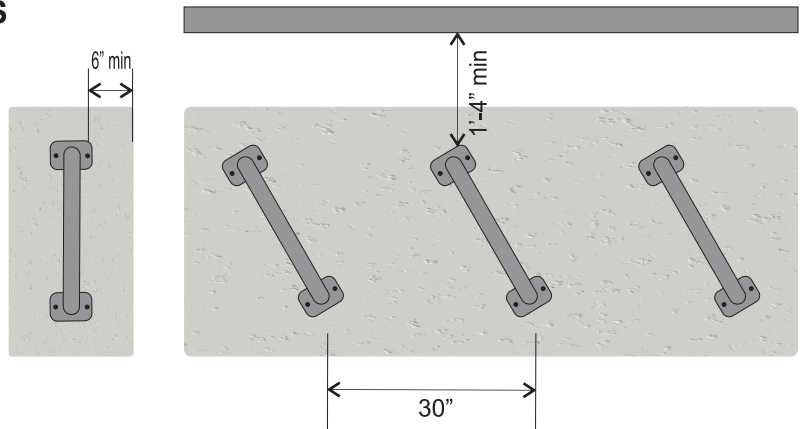

## Rack Layout

The recommended spacing between racks is 36 inches, with a minimum spacing of 24 inches, although this type of rack is commonly installed at 30 inches on center. The size of the concrete pad should be adjusted to accommodate the number of racks being installed, at the chosen spacing. Allow a minimum of six inches of concrete as measured from the outermost anchors to the edge of the concrete pad.

One advantage of this type of rack is that bikes can be parked from either side, or from the same side. This means that the racks can be installed close to a wall or adjacent structure since access is only needed from one side. In the event of a single sided installation, allow a minimum of 16 inches from any adjacent structure.

Racks can be installed perpendicular to the concrete pad, or at an angle of about 30 degrees. An angled installation can help to reduce the total depth of space required to park bikes.

## Anchoring the Staple Rack

The racks can be anchored as required using the standard concrete wedge anchors provided. Use the rack as a template to locate the holes; two per mounting plate.

Using a 1/2" masonry drill bit, drill holes in the concrete to a depth of approximately 3".

Place the anchors into the holes and hammer them down until they bottom out in the hole.

Note: push the anchors through the holes of the positioned rack and hammer them into place. Setting the anchors in the concrete prior positioning the rack will make aligning the holes difficult.

Tighten each anchor until the anchors set into the concrete. Note that during tightening, the anchor will lift out of the concrete a little; this is normal.

If desired, the tops of the anchors may be cut off for a cleaner appearance.

## Anchoring Detail

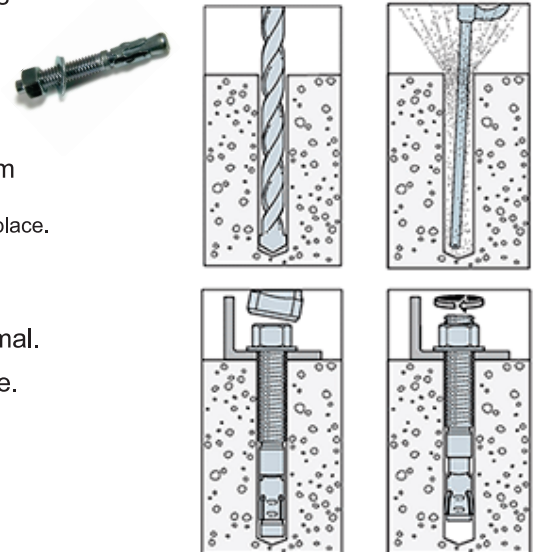

# URBAN RACKS

INNOVATIVE | BICYCLE PARKING

1-888-717-8881 sales@urbanracks.com

For more product and company information,  
please visit us at [www.urbanracks.com](http://www.urbanracks.com)